

SPECIFICATION

Product Name: Ultrasonic Oxygen Sensor

Sensor Item No.: Gasboard-7500H

Gasboard-7500HA

Gasboard-7500H-RH

Gasboard-7500HA-RH

Version: V1.0

Date: August 11, 2020

Revision

No.	Version	Content	Reviser	Date
1	V1.0	First Edition	Wendy Hao	2020-08-11

Ultrasonic Oxygen Sensor Module Gasboard-7500H Series

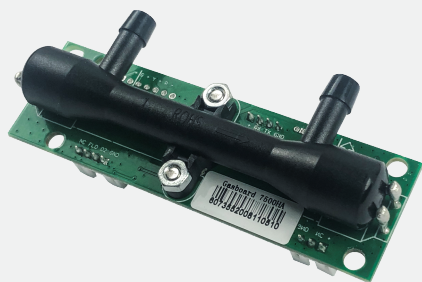

Applications

- ✧ Family and Medical Oxygen Concentrator/Generator
- ✧ Medical Ventilator
- ✧ PSA Oxygen Concentrator and Oxygen Generator
- ✧ Respiratory Device, Anesthetic Machine and Vaporizer

Description

Gasboard-7500H series are a type of ultrasonic oxygen gas sensors, which can realize accurate and stable measurements for oxygen concentration and flow rate. Gasboard-7500H series provide a new, economical, durable option for system designers who is seeking for medical oxygen sensor for PSA oxygen generator, medical ventilator, respiratory device, anesthetic machine and vaporizer. By adopting ultrasonic detecting technology and principle of TOF (time of flight) measurement, Gasboard-7500H series have great performances: excellent stability, high accuracy, fast response, continuous monitoring, no drift, no need routine calibration, maintenance-free, etc.

Features

- ✧ Ultrasonic measurement technology, for both oxygen concentration and flow rate
- ✧ Based on principle of TOF (time of flight) measurement, continuous monitoring, no drift, no need routine calibration, maintenance-free.
- ✧ Excellent stability, high accuracy, fast response
- ✧ Full scale matrix temperature compensation (humidity is also available)
- ✧ No-consuming parts, long Lifespan
- ✧ Small size, flexible installation
- ✧ High performance-cost-ratio
- ✧ Support serial port and analog output accurate measurements
- ✧ Enhanced EMC performance
- ✧ RoHS, REACH, CMC, CE certificated

Working Principle

Principle of ultrasonic flow detection: when ultrasonic wave is propagating in the fluid, it is affected by the fluid velocity and carries the flow velocity information. The flow velocity can be measured by detecting the received ultrasonic signal, so as obtain the flow rate. Ultrasonic flow measurement has the characteristics of not impeding fluid flow.

Ultrasonic concentration detection theory: when the binary gas mixture composition has molecular weight difference, sound travel speed varies from different gas composition.

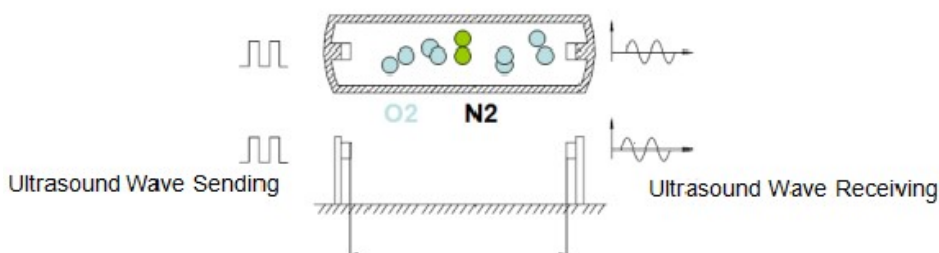

Specification

Ultrasonic Oxygen Sensor Specification	
Detect Principle	Ultrasonic Technology
Detection Range	O2 Concentration: 20.5%~95.6% ^① Flow Rate: 0~10L/min
Detection Accuracy	O2 Concentration: $\pm 1.5\%FS @ (5\sim 45) ^\circ C$ ^② Flow Rate: $\pm 0.2L/min @ (5\sim 45) ^\circ C$
Resolution	O2 Concentration: 0.1% Flow Rate: 0.1L/min
Response Time	O2 Concentration: <1.5S Flow Rate: <0.3S
Analog output	O2 Concentration: 0-2.5V (DC) Flow Rate: 0-2.5V (DC) This function is just for 7500HA & 7500HA-RH
Work Condition	-5~50 $^\circ C$; 0~95%RH (Non-condensing)
Storage Condition	-20~60 $^\circ C$; 0~95%RH (Non-condensing)
Work Voltage	DC 4.75-12.6V, Ripple Wave <50mV
Work Current	Average Current <16mA; Peak Current<35mA
Communication Interface	UART_TTL (3.3V)
Product Size	W80*H22*D25 mm
Life Span	≥ 5 Years

Remark① Oxygen concentration detection range 20.5%~95.6% is calibrated with PSA oxygen source.

If use 99.99% pure oxygen as oxygen source, should add a coefficient to make a transfer,

The formula is: Target concentration = (sensor reading * 1.142) - 3.42

Pure oxygen 99.99% range version is also available, please contact Cubic team.

The reading value<20.5% is off as default, please contact Cubic if necessary.

Remark② $\pm 1.5\%FS @ (5\sim 45) ^\circ C$ is for 7500H and 7500HA O₂ concentration detection accuracy.

O₂ concentration detection accuracy for 7500H-RH&7500HA-RH is $\pm 1.8\%FS @ (5\sim 45) ^\circ C$ if use the test gas mixed with atmosphere and oxygen.

7500H, 7500HA, 7500H-RH Functional Differences				
Item No.	Size	Basic Measuring Parameters	Functional Difference	Measuring Parameters Difference
7500H	Same	Same	Temperature compensation	O2 concentration: $\pm 1.5\%FS @ (5\sim 45) ^\circ C$
7500HA	Same	Same	Temperature compensation and analog output	O2 concentration: $\pm 1.5\%FS @ (5\sim 45) ^\circ C$
7500H-RH	Same	Same	Temperature and humidity compensation	O2 concentration: $\pm 1.8\%FS @ (5\sim 45) ^\circ C$
7500HA-RH	Same	Same	Temperature & humidity compensation and analog output	O2 concentration: $\pm 1.8\%FS @ (5\sim 45) ^\circ C$

Pin Definition

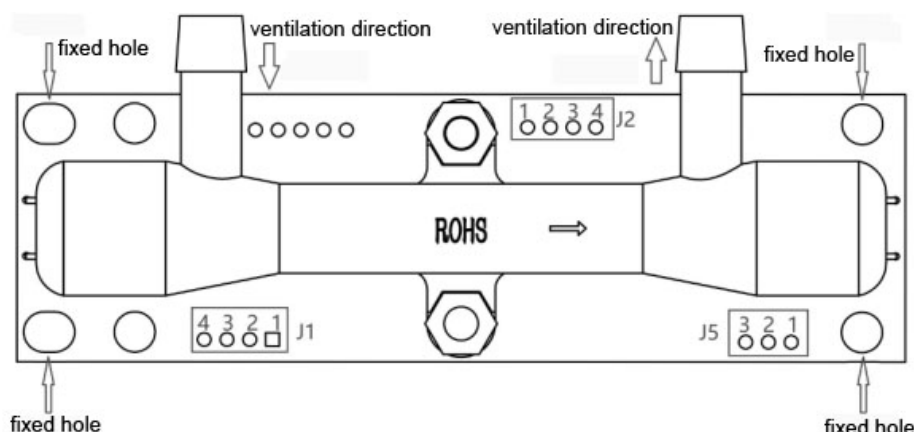

Drawing1 Gasboard-7500H Series Pin Definition

Table 1. Connector Pin Definition

J2			J5		
NO	Pin	Description	NO	Pin	Description
1	Vcc	4.75-12.6V, External Power Supply Input Pin	1	Vcc	4.75-12.6V, External Power Supply Input Pin
2	Rx	UART-Rx Receiving (3.3V)	2	NC	No Definition
3	Tx	UART-Rx Sending (3.3V)	3	GND	Power Supply Input
4	GND	Power Input			
Remark: J2 Definition is for 7500H, 7500HA, 7500H-RH, 7500HA-RH			Remark: J5 Definition is for 7500H, 7500HA, 7500H-RH, 7500HA-RH		
J1					
NO	Pin	Description			
1	GND	Analog output			
2	O ₂	0V-2.5V output pin, 0V corresponds to 0%Vol oxygen concentration; 2.5V corresponds to 100%Vol oxygen concentration			
3	Flow	0V-2.5V output pin, 0V corresponds to flow rate of 0L/min 2.5V corresponds to flow rate of 10L/min			
4	NC	Open			

Remark: J1 Definition is only for 7500HA&7500HA-RH

Table 2. Connector Description

Port	Terminal	Connector	Pin Pitch
J1	PH2.0-4A	PH2.0-4P	2.00mm
J2	PH2.0-4A	PH2.0-4P	2.00mm
J5	PH2.0-3A	PH2.0-3P	2.00mm

Reference Circuit

Application Scenarios: UART 3.3V Output

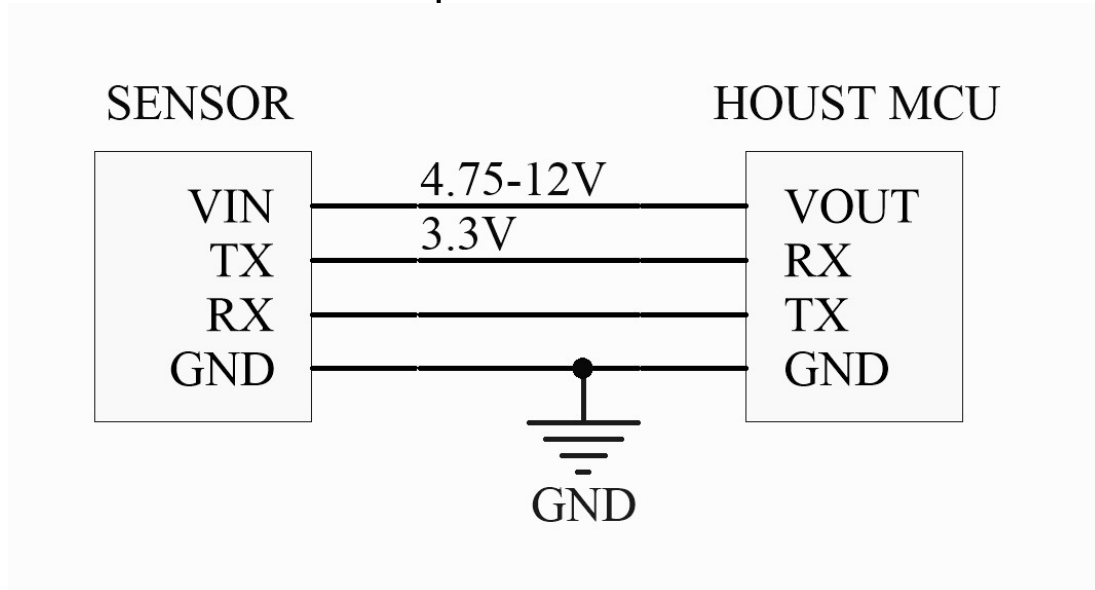

Drawing 2 UART Communication Connection Circuit

Communication Protocol

UART Communication Protocol

1. Protocol Overview

- 1) Baud Rate: 9600, Data Bits: 8, Stop Bits: 1, Parity: No, Flow Control: No
- 2) The protocol data are hexadecimal data. For example, "46" is [70] in decimal;
- 3) [xx] is single byte data(unsigned,0-255); In double byte, the high byte is in front of low byte;
- 4) The default is active sending, and the sending cycle is 0.5 seconds. If you need to read more other data, send the corresponding command directly to the host, and the host responds immediately.

2. Serial Communication Protocol Format

PC Send Format

Start Symbol	Length	Order No	Data 1	Data n	Check Sum
HEAD	LEN	CMD	DATA1	DATAn	CS
11H	XXH	XXH	XXH	XXH	XXH

Protocol Format Description

Protocol Format	Description
Start Symbol	PC sending is fixed to [11H], module response is fixed to[16H]
Length	Length of frame byte, =data length+1 (include CMD+DATA)
Order No	Directive number
Data	Read or written data, the length is variable
Check Sum	The sum of data accumulation, =256-(HEAD+LEN+CMD+DATA)

3. Serial Protocol Order Number List

No	Function Name	Order No
1	Read the measurement result of O2	0x01
2	Read the software version number	0x1E
3	Inquiry instrument serial number	0x1F
4	Open reading value<20.5%	0x02

4. Detailed Description

4.1 Read the Measurement Result of O2

Send: 11 01 01 ED

Response: 16 09 01 DF1-DF8 [CS]

Function: Read the measurement result of O2

Description: O2 Concentration = (DF1*256 + DF2) /10 (Vol %)

O2 Flow Value = (DF3*256 + DF4) /10 (L/min)

O2 Temperature Value = (DF5*256 + DF6) /10 (°C)

Notice: DF7-DF8 reserve

Remark: The default is active data sending. The sensor can also output the value automatically without sending the command.

When send 11 01 07 E7, can change active data sending mode to request-response mode.

Communication Protocol

Response Example:

Response: 16 09 01 00 CD 00 00 00 C2 00 1E 33

Instruction:

Hexadecimal Convert into Decimal: CD is 205; C2 is 194

O2 Concentration = $0 \times 256 + 205 = 205$ (20.5%)

O2 Flow Value = $0 \times 256 + 0 = 0$ (L/min)

O2 Temperature Value = $0 \times 256 + 194 = 194$ (19.4°C)

4.2 Read the Software Version Number

Send: 11 01 1E D0

Response: 16 09 1E DF1-DF8 [CS]

Function: Read the software version number

Instruction: DF1-DF8 refers to the ASCII code of particular version number

For example: When module version number is 0.02.016, response data:

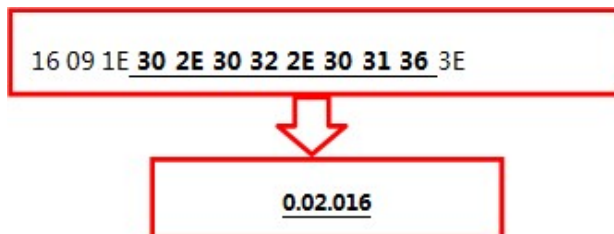

Hexadecimal Convert into ASCII Code:

4.3 Inquiry Instrument Serial Number

Send: 11 01 1F CF

Response: 16 0B 1F (SN1) (SN2) (SN3) (SN4) (SN5) [CS]

Function: Read version number for module firmware

Explanation: Instrument serial number of output software. SNn range is 0~9999, 5 integer type constitute 20 serial number

4.4 Open reading value < 20.5%

Send: 11 02 02 00 EB

Response: 16 0C 02 00 DF1 DF2 DF3 DF4 DF5 DF6 DF7 DF8 DF9 DF10 [CS]

Function: Read the measurement result of O2 (0-100%)

O2 flow = $(DF9 \times 256 + DF10) / 10$ (L/min)

O2 concentration = $(DF7 \times 256 + DF8) / 10$ (Vol %)

O2 temperature = $(DF5 \times 256 + DF6) / 10$ (°C) (gas temperature in Sensor chamber)

Example:

Response: 16 0C 02 00 5D 90 5D 7E 00 C2 00 CD 00 00 7B

Instruction:

Hexadecimal Convert into Decimal: CD is 205; C2 is 194

O2 Concentration = $0 \times 256 + 205 = 205$ (20.5%)

O2 Flow Value = $0 \times 256 + 0 = 0$ (L/min)

O2 Temperature Value = $0 \times 256 + 194 = 194$ (19.4°C)

Dimension

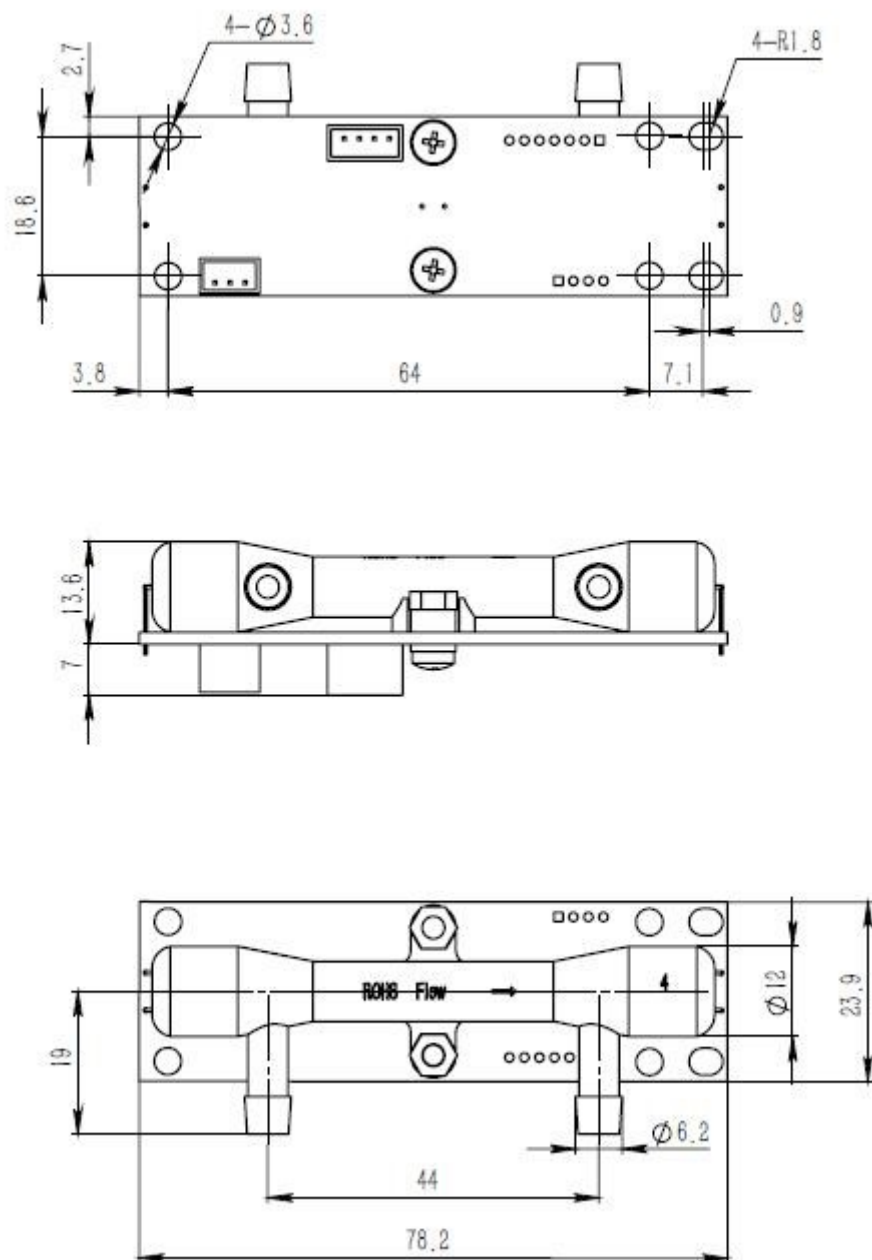

Drawing 3 (Unit: mm, Tolerance: $\pm 0.2\text{mm}$)

Product Code Instruction

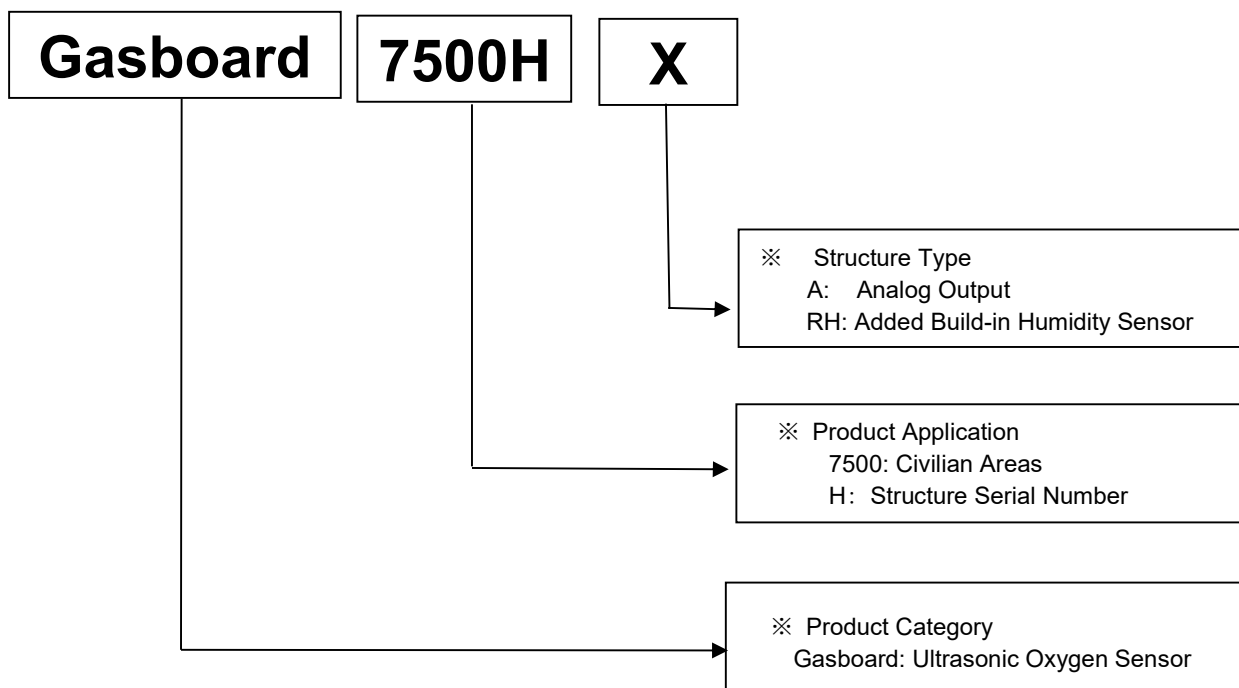

Reliability Testing

Item	Requirement	Criterion	Sample (n) Failed (c)
Flow Performance	Indoor temperature requirement: $25\pm 2^{\circ}\text{C}$, humidity $(50\pm 10)\% \text{RH}$, after the sensor connect with serial port and power on, switch over the flow in 3L/min、5L/min、8L/min respectively to make measurement of oxygen concentration and accuracy.	Make new tests in different oxygen flow, all can meet deviation criterion.	n=70 c=0
Low Temperature Storage	Storing the sensor for 96H with no power under $-20^{\circ}\text{C}\pm 2^{\circ}\text{C}$ environment condition, then test the measuring deviation under normal temperature condition.	After staying under normal temperature condition for 2 hours, the test all can meet deviation criterion.	n=0 c=0
Low Temperature Operation	Indoor temperature requirement: $-10\pm 2^{\circ}\text{C}$, test the measuring deviation of sensor under normal temperature condition after operating for 96H with electricity.	After staying under normal temperature condition for 2 hours, the test all can meet deviation criterion.	
High temperature Storage	Storing the sensor for 96H with no power under $60^{\circ}\text{C}\pm 2^{\circ}\text{C}$ environment condition, then test the measuring deviation under normal temperature condition.	After staying under normal temperature condition for 2 hours, the test all can meet deviation criterion.	
High Temperature Operation	Indoor temperature requirement: $50\pm 2^{\circ}\text{C}$, test the measuring deviation of sensor under normal temperature condition after operating for 96H with electricity.	After staying under normal temperature condition for 2 hours, the test all can meet deviation criterion.	
High-low Temperature Shock	Keep the sensor under -20°C for 60 mins, then switch it to 60°C in 10s and stay for another 60 mins, this is one cycle. Totally 10 cycles with the sensor power off.	After staying under normal temperature condition for 2hours, the sensor accuracy should meet the specification standard.	
High Temp & Humidity	Keep the sensor under high temp & humidity ($40\pm 2^{\circ}\text{C}$, 95%RH), after working under rated voltage for 500H, test the measuring deviation under normal temperature condition.	After staying under normal temperature condition for 2hours, the sensor accuracy should meet the specification standard.	n=2 c=0
Salt Spray Test	Standard: GB/T2423.17, place the sensor in the salt fog box under 35°C and spray it with Nacl solution (concentration is 5%) for 24 hours, then flushing it with distilled water and drying it with airflow.	Keep the sensor under standard environment more than 1h and less than 2 h, it should no appearance defect, no corrosion.	
Vibration Test	Bare sensor should bear the specified vibration test in X/Y/Z direction, frequency range 10~55~10Hz/min, amplitude 1.5mm, scan circulation 2 hours.	No appearance defect after vibration test, the sensor can meet basic performance test standard.	n=4 c=0
Package Drop Test	Drop height: setting the height as specified weight according to standard GB/T 4857.18. Making the drop test according to the GB/T4857.5 standard. Test sequence is one corner, three edges, six sides.	No appearance defect after drop test, no components fall off, the sensor should work normally.	n=1 ctn c=0

Packing Information

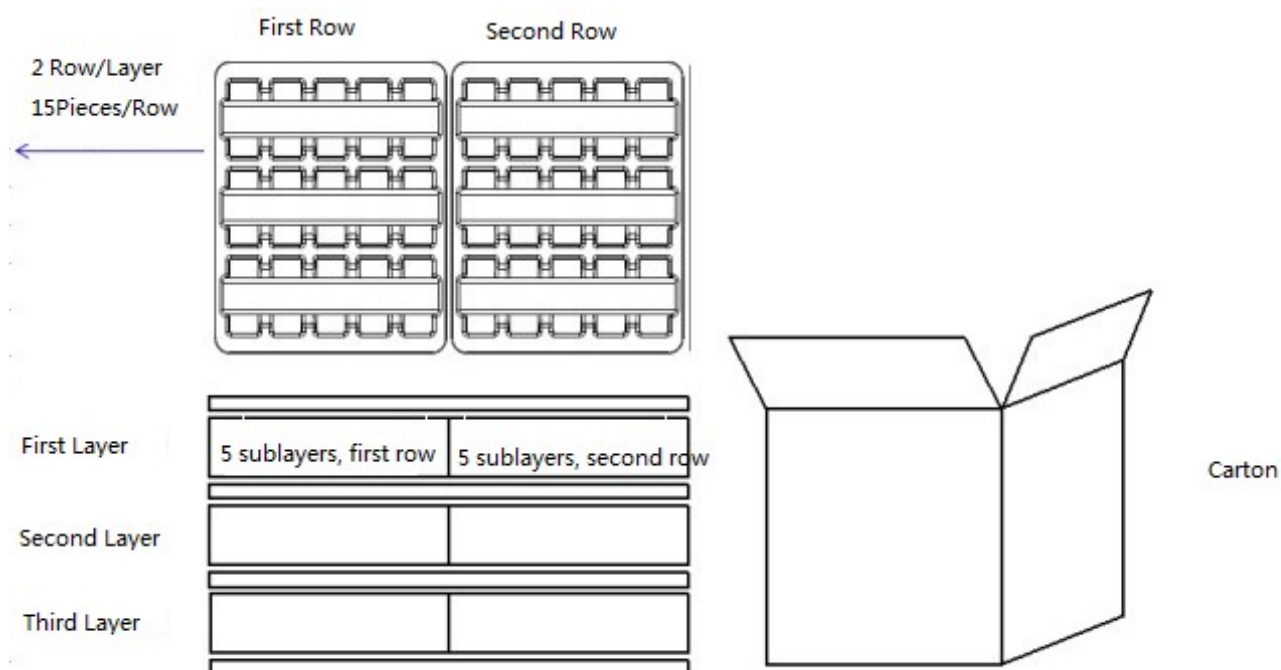

Qty/Layer	Small Tray Qty	Big Tray Qty	Sensor per Carton	Carton Dimension	Packing Material
30 pcs	5 layers	3 layers	450pcs	W395 * L320 * H470mm	Anti-static Plastic Tray

User Attention

Please pay attention to below:

- (1) Install the sensor as far away as possible from the heat source and heat dissipation outlet of the compressor, and install the sensor as close as possible to the oxygen outlet, and install a one-way valve to prevent the water from humidifying glass from entering sensor.
- (2) In order to ensure reliability and long service life, do not use or store the sensor in a place where the temperature is higher than the rated temperature, and do not use the sensor in an environment where the voltage is higher than the rated voltage of the sensor.
- (3) Without necessary compensations, please do not use the sensor in the environments of high humidity water steam, abnormal pressure, and low temperature.
- (4) The product shall not be used or stored in a place with corrosive gas, especially hydrogen sulfide gas, acid, alkali, salt or similar. The products stored in the warehouse should be stored in normal temperature and humidity, and avoid direct sunlight.
- (5) When there is a problem with the Cubic's products, please contact Cubic team in time; the sensor must not be disassembled privately, and Cubic will not bear any consequences if it is damaged by disassembled privately.

Consultancy & After-sales Service

Contact Number: 86-27-8162 8827

Address: Fenghuang No.3 Road, Fenghuang Industrial Park, Eastlake Hi-tech Development Zone,
Wuhan, China

Postal Code: 430205

Fax: 86-27-8740 1159

Website: <http://www.gassensor.com.cn>

E-mail: info@gassensor.com.cn